



KEY FEATURES

- Compact dual 10-inch passive line array element
- Highest power-to-size ratio in the Axiom product line
- Three-way design with coaxial compression driver and extended waveguide operation
- Enhanced sensitivity and clarity through the vocal frequency range
- Second-generation directive control with improved rear rejection
- Phenolic birch plywood construction for touring and installation durability
- Optimized for Axiom Q-Nex amplification and DSP processing
- Consistent front-to-back coverage with minimal equalization requirements

TECHNICAL SPECIFICATIONS

SYSTEM

System's Acoustic Principle	Line Array Element, LF Transmission Line, Broadband directivity control
Frequency Response (-6dB)	65 Hz – 18kHz (Processed)
Horizontal Coverage	100° deg Avg., from 400Hz to 18kHz; 160° Avg. from 65 Hz to 400Hz
Vertical Coverage	Array Size dependent
Sensitivity 2.83V	98 dB SPL @ 1m (LF) - 114 dB SPL @ 1m (HF)
Maximum (peak) Output	146 dB SPL (AES 75 Standard)

TRANSDUCERS

LF	Two 10" (260mm) Dual Gap, 3.5" (88mm) ISV, Neodymium Woofers, 16Ω each, paralleled
HF	Two 1.4", two way, Coaxial Neodymium driver, 3" (64mm) midrange voice coil, 2" (51mm) high voice coil, 16Ω each, paralleled

INPUT CONNECTORS

Connector Type	Neutrik® speakON™ NL4MP x 2
Input Wiring	LF = Pin 1+/1- HF = Pin 2+/2-

POWER HANDLING

Input Power Rating (AES)	1600W LF + 280W MHF
Input Power Handling (Program)	3200W LF + 560W MHF

ENCLOSURE & CONSTRUCTION

Dimensions (W x H x D)	942 mm (W) x 295 mm (H) x 650 mm (D)
Enclosure Material	15/30mm, reinforced Phenolic Birch
Paint	High resistance, water based paint
Flying System	External Frame suspension system, back hinge
Net Weight	55 Kg (121.3 lbs.)



DESCRIPTION

The Axiom AX2022P is a compact dual 10-inch line array element designed to deliver exceptional output and presence from a remarkably efficient physical footprint. Offering the highest power-to-size ratio in the Axiom product line, the AX2022P provides the scale, impact, and projection typically associated with larger systems, while maintaining the flexibility required for both touring and fixed installation applications.

TRANSDUCERS

The AX2022P features a three-way, fully passive transducer configuration centered around a coaxial compression driver paired with an advanced waveguide. This architecture enables the waveguide—traditionally optimized for high-frequency reproduction—to operate effectively into the midrange. By extending controlled directivity through a wider operating bandwidth, the AX2022P achieves increased sensitivity and reduced distortion across the critical vocal band, resulting in improved intelligibility and clarity at all output levels.

Two high-performance 10-inch transducers handle the remaining mid- and low-frequency reproduction, engineered for fast transient response and consistent output under sustained load. The integration of these elements within a carefully tuned enclosure ensures musical, controlled performance across the lower spectrum while maintaining consistent phase coherence.

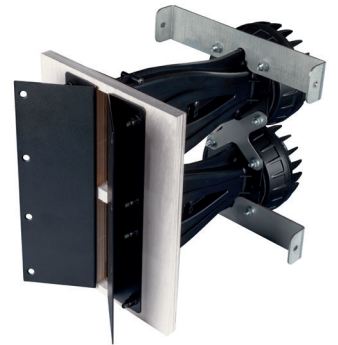

SYSTEM CONCEPT AND SONIC PERFORMANCE

Constructed from phenolic birch plywood, the AX2022P features a robust enclosure developed to withstand the demands of both touring and permanent installation environments. Second-generation directive control technology is employed to manage rear-facing energy, improving rejection and minimizing unwanted interactions with reflective surfaces and adjacent array elements.

The result is consistent tonal balance from front to back of the venue—natural voice reproduction and musical integrity are preserved whether addressing the first row or the rear balcony. This behavior simplifies system design and reduces the need for corrective equalization, allowing engineers to focus on the performance rather than fighting the room.

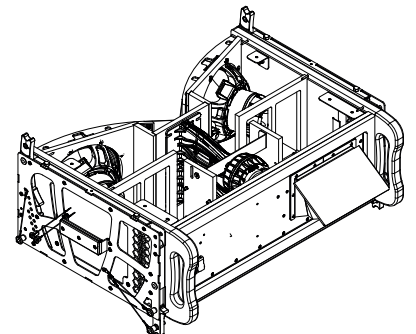

SYSTEM INTEGRATION

The AX2022P integrates seamlessly with Axiom's Q-Nex amplifier platform, which provides optimized DSP processing, comprehensive system protection, and scalable power delivery. This pairing ensures that the enclosure performs to specification across varying signal levels and deployment configurations, delivering repeatable results with minimal setup time.



AX2022P frequency response

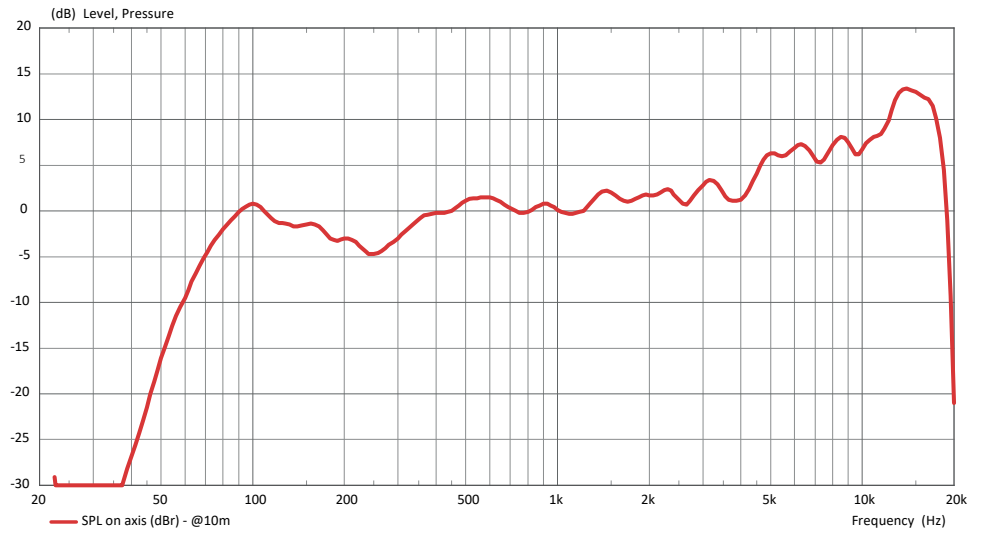

AX2022P HORIZONTAL directivity map

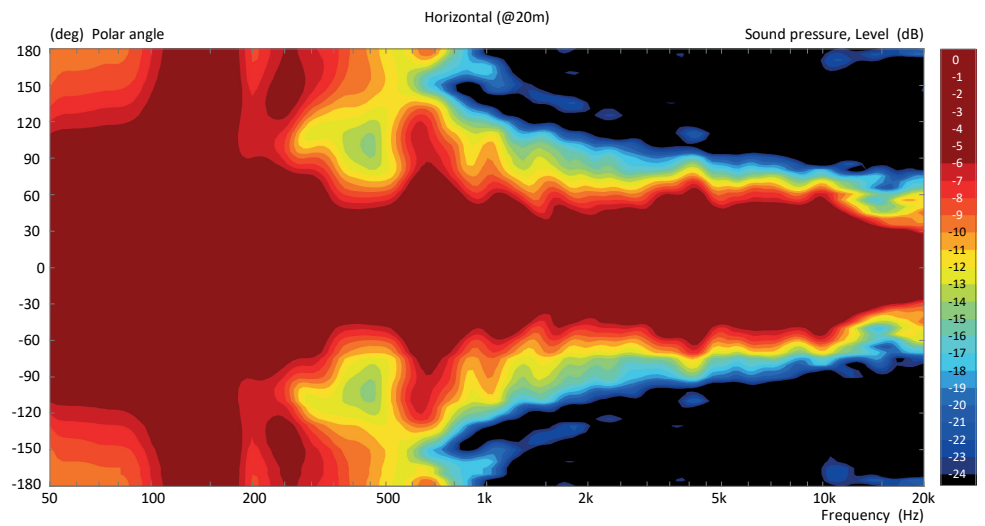

AX2022P VERTICAL directivity map

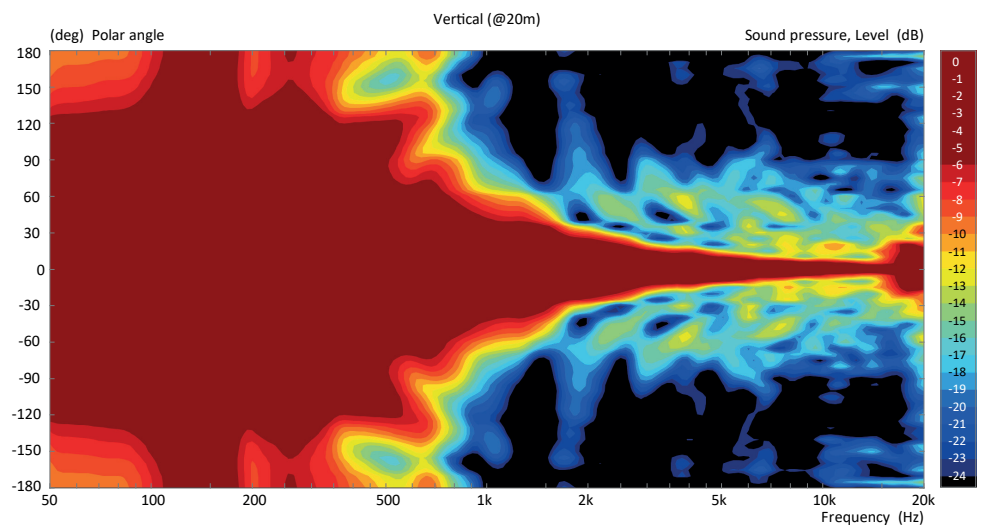

AX2022P HF HORIZONTAL polar diagram

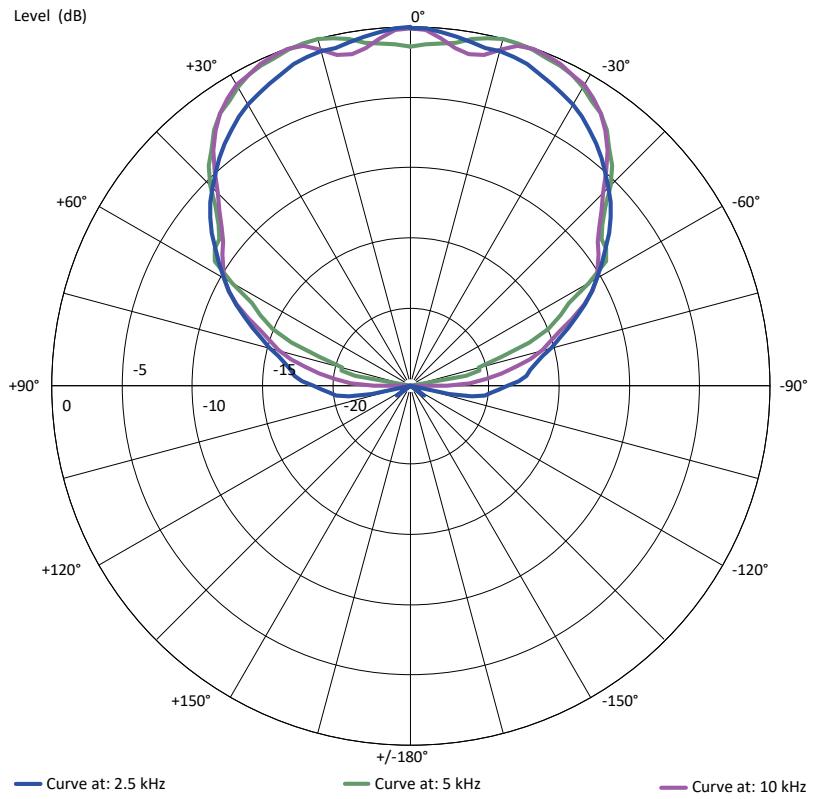

AX2022P HF VERTICAL polar diagram

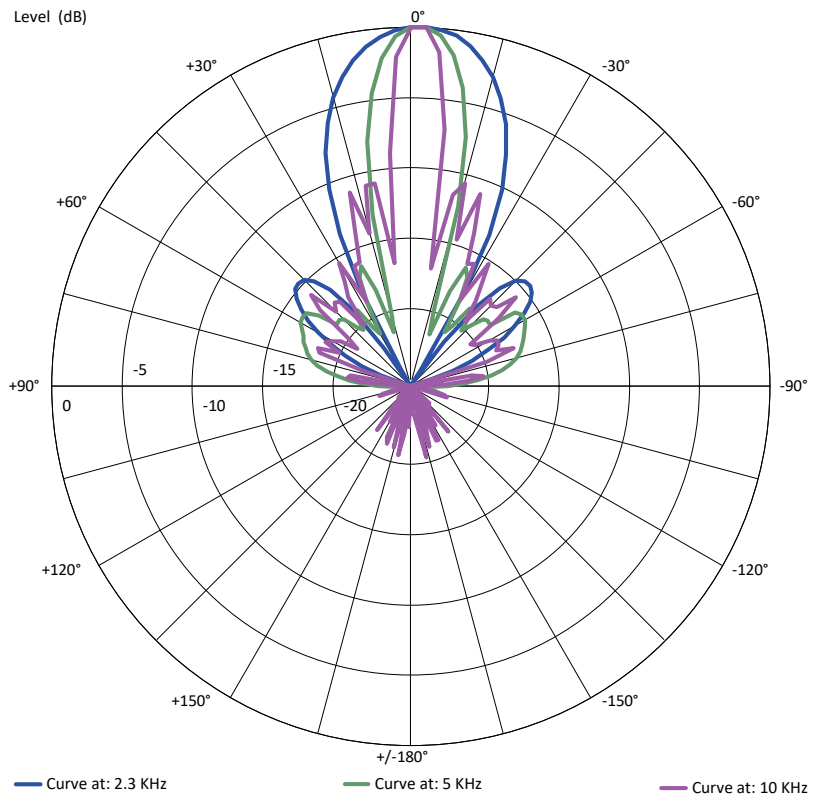

AX2022P LF HORIZONTAL polar diagram

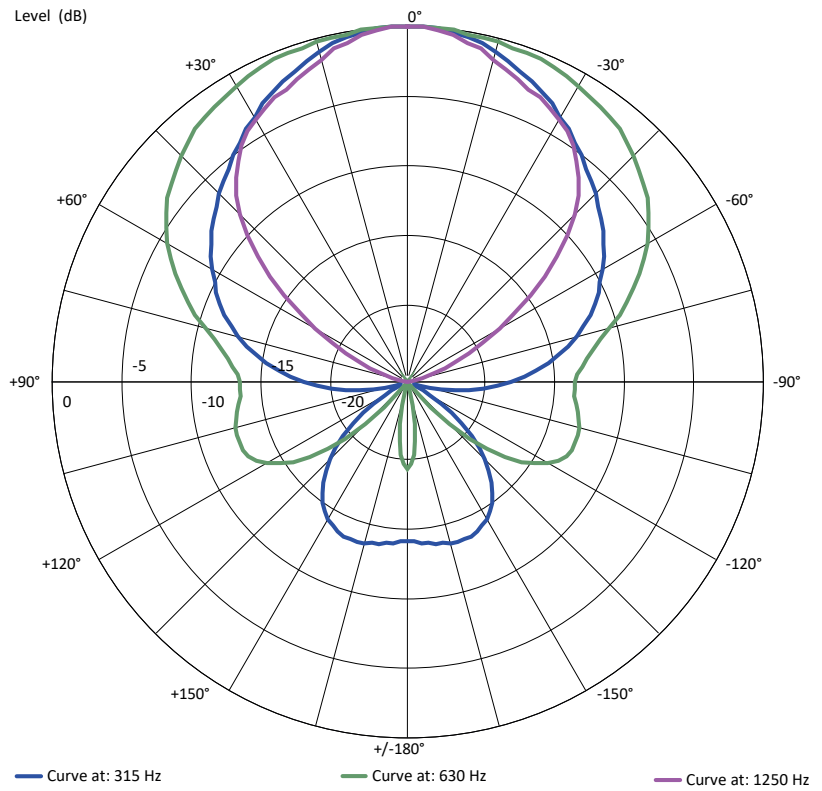

AX2022P LF VERTICAL polar diagram

